

12V C.C. - D.C.

VA36-A101-46A
VA36-A101-46S

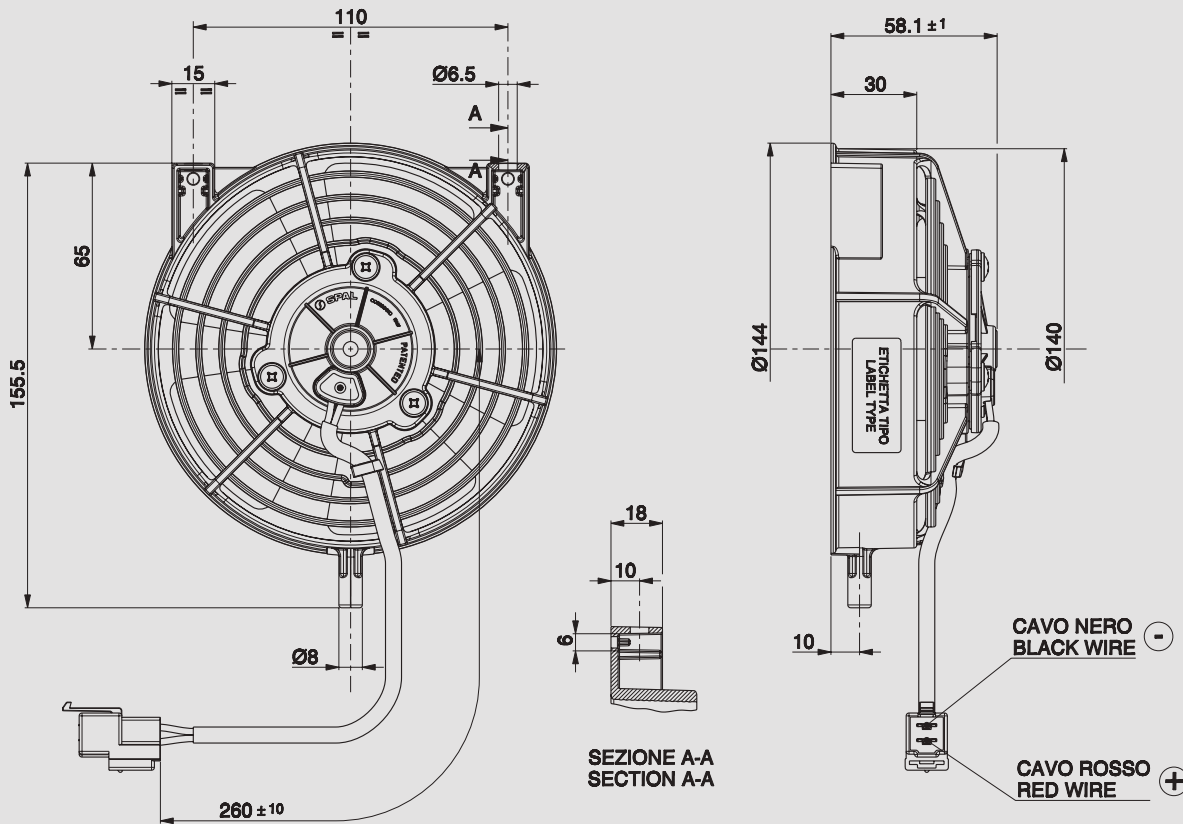

Connector SUMITOMO Code 6010-2802
SUMITOMO terminal Code 1800-2093
Suggested mounting torque: 3(+1/-0) Nm with screw M5
Weight 0,42 Kg. approx.

Connettore SUMITOMO Cod. 6010-2802
Terminali SUMITOMO Cod. 1800-2093
Coppia di serraggio consigliata: 3(+1/-0) Nm con vite M5
Peso 0,42 Kg. circa

Ø 130 mm
Ø 5,2"

suction / aspirante

blowing / soffiante

PRODUCT FEATURES
CARATTERISTICHE PRODOTTO

Static pressure Pressione statica mm H ₂ O	suction / aspirante			blowing / soffiante			
	Airflow Portata m ³ /h	Current input Corrente assorbita A	Airflow Portata CFM	Airflow Portata m ³ /h	Current input Corrente assorbita A	Airflow Portata CFM	
0	480	4,3	283	440	4,1	260	0
2,5	460	4,3	271	410	4,1	242	0,1
5	430	4,4	254	380	4,2	224	0,2
7,5	410	4,5	242	340	4,3	201	0,3
10	380	4,6	224	300	4,4	177	0,4
12,5	350	4,8	207	250	4,6	148	0,5
15	310	4,9	183	220	4,8	130	0,6
17,5	250	5,0	148	180	5,0	106	0,7
20	190	5,1	112	140	5,1	83	0,8
25	130	5,4	77	0	5,9	0	1
30	70	5,6	41				1,2
35	20	5,9	12				1,4
40	0	6,0	0				1,6

Waterproof motor, IP 68
Motore chiuso, IP 68



Waterproof connector
Connettori a tenuta stagna



✓ = Standard feature
Caratteristiche standard

✓ = Available upon request
Disponibile su richiesta

Test voltage 13 V. d.c. - Tensione di prova 13 V. c.c.